

# Stationary concrete pump

# BSA 14000 HP D5

Output up to 84 m<sup>3</sup>/h  
Delivery pressure up to 231 bar

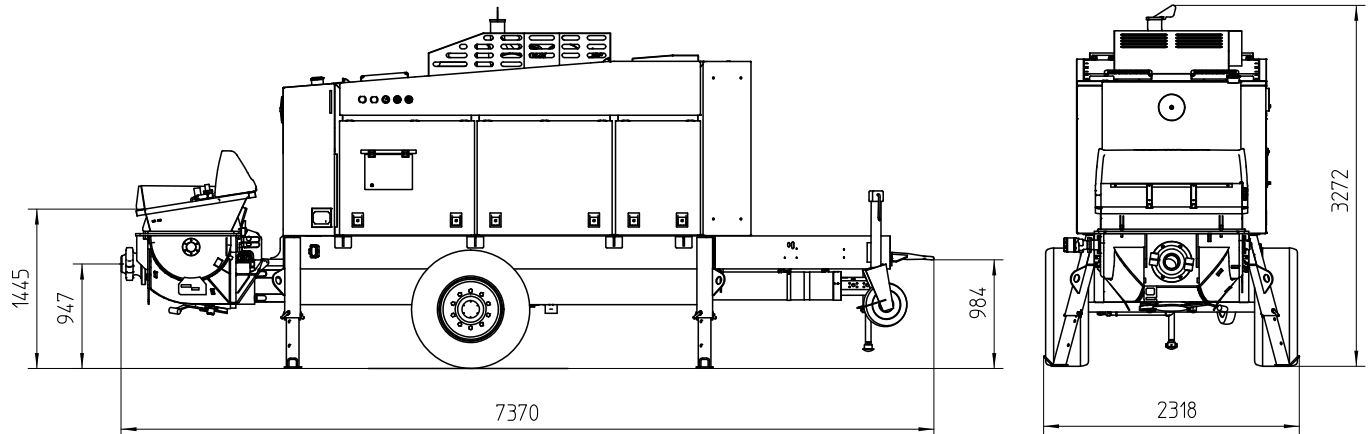

Note: Standard version BSA 14000 HP D5. Dimensions and weights depend on equipment. Subject to technical modifications and errors.

## Technical data

Model		BSA 14000 HP D5
Material number		102485.000
Output	m <sup>3</sup> /h	84 / 57 *
Delivery pressure	bar	158 / 231 *
Delivery cylinder	Ø mm	180
Delivery cyl. stroke	mm	2100
Strokes / minute		26 / 13 *
Engine power	kW	470
Hopper		RS 905 HF
Capacity	l	600
Filling height	m	approx. 1.3
Transfer tube		S 1812 D
Line connection	mm	ZX 125
Pressure connection	"	8
Control system		EPS FFH
Weight	kg	10800

\* Values for hydraulic fluid being fed to piston-side  
All data maximum theoretical

## Serial equipment

Agitator safety switch off	Flushing water pump
Balloon tyres incl. transport protection	160 l/min 25 bar
Cable remote control 10 m	Gate valve connection
Central lubrication on hopper, electrical	Grill 60 mm
Cleaning accessories	Hard metal wear parts
Coloring: Pump, frame, roof and tank anthracite grey; cover chrome yellow	Operating manuals (1× paper, 1× CD-ROM) spare part list
Concrete hopper with agitator	Pump flow meter
Concrete output adjust, electrically	Set-up foot hydraulically
Concrete pressure adjust, electrically	Speed drawdown automatically on pump stop
Coupling ring (DIN)	Splash guard
Drive diesel, CAT 470 kW, Stage 5	Square outriggers 4× mech. 15°-slange
Electronic error management	Tool set incl. standard equipment
Ergonic Graphic Display (EGD)	Trailer F8, can be driven on job site

See quotation for exact serial delivery scope.  
Comprehensive range of options available on request.